

Vandal Resistant® CP-BS Lead Safe™ J/V Wall Sink Set – W/ 165 Fixed Spout & V/R Aerator

PRODUCT CODE:

- 174.54.22.03

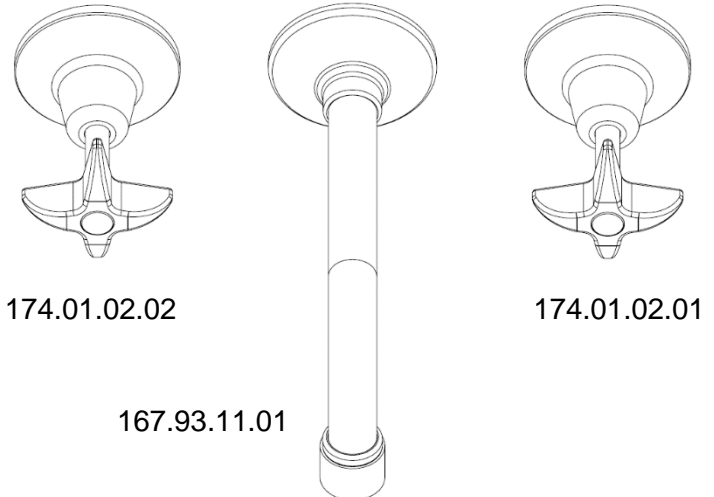

For Watermark and/or WELS information of KITS, refer to each individually certified component.

Item Code:	Description	Watermark	WELS
174.54.22.03	Vandal Resistant® CP-BS Lead Safe™ J/V Wall Sink Set (NSW) W/ 165 Fixed Spout & V/R Aerator	*	*
Components:			
167.93.11.01	GalvinLab® CP-BS Lead Safe™ Wall Through Outlet 165 W/ V/R Aerator	YES	YES
174.01.02.01	Vandal Resistant CP Lead Safe™ J/V Wall Top Assembly Cold	YES	N/A
174.01.02.02	Vandal Resistant CP Lead Safe™ J/V Wall Top Assembly Hot	YES	N/A
Notes:			
1. N/A—Not applicable.			
2. * — The item is a KIT .			
3. A copy of each component's Installation Instructions can either be downloaded from www.galvinengineering.com.au or found inside the packaging.			
4. Kit components may be purchased separately.			

INSTALLATION

INSTALLATION COMPLIANCE: Galvin Engineering products must be installed in accordance with these installation instructions and in accordance with AS/NZS 3500, the PCA and your local regulatory requirements. Water and/or electrical supply conditions must also comply to the applicable national and/or state standards. Failing to comply with these provisions shall void the product warranty and may affect the performance of the product.

TROUBLESHOOTING

PROBLEM	CAUSE	RECTIFICATION
Water is not flowing from tap	Water supply is turned off	Turn on water supply
	Obstruction on spout	Check if there are obstructions hindering the water flow in the spout and take it out.
Assembly is leaking	Ensure thread tape was used when the assembly was installed	Repeat installation steps ensuring thread tape is used to seal the assembly
Inconsistent flow	The supplied tap washer wasn't installed.	Repeat installation steps ensuring the tap washer is correctly in place
Tap is leaking	Worn jumper valve.	Remove the top assembly and replace the jumper valve
Rate of flow inadequate	The flow restrictor may not be satisfactory due to inadequate supply pressure	Remove flow restrictor and replace with a flow restrictor of different capacity to suit (available from Galvin Engineering)

WARRANTY

Galvin Engineering products are covered under our Manufacturer's Warranty. Galvin Engineering products must be installed in accordance with the installation instructions and in accordance with AS 3500 and NCC Volume Three, relevant Australian Standards and local authorities applicable to product being installed. Water and electrical supply conditions must also comply to the applicable national and/or state standards, failing to comply with these provisions may void the product warranty and affect performance of the product.

Please visit www.galvinengineering.com.au to view the full warranty, our Installation Compliance and Maintenance & Cleaning information as well as any other additional information.